

# New England's Electric Power System

- 14 million people; 6.5 million households and businesses
- 350+ generators/power plants
- 8,000+ miles of transmission lines
- 12 interconnections to neighboring systems
- 32,000 MW total supply
- All-time peak demand: August 2, 2006 – 28,127 MW
- Eight (8) Pricing Zones

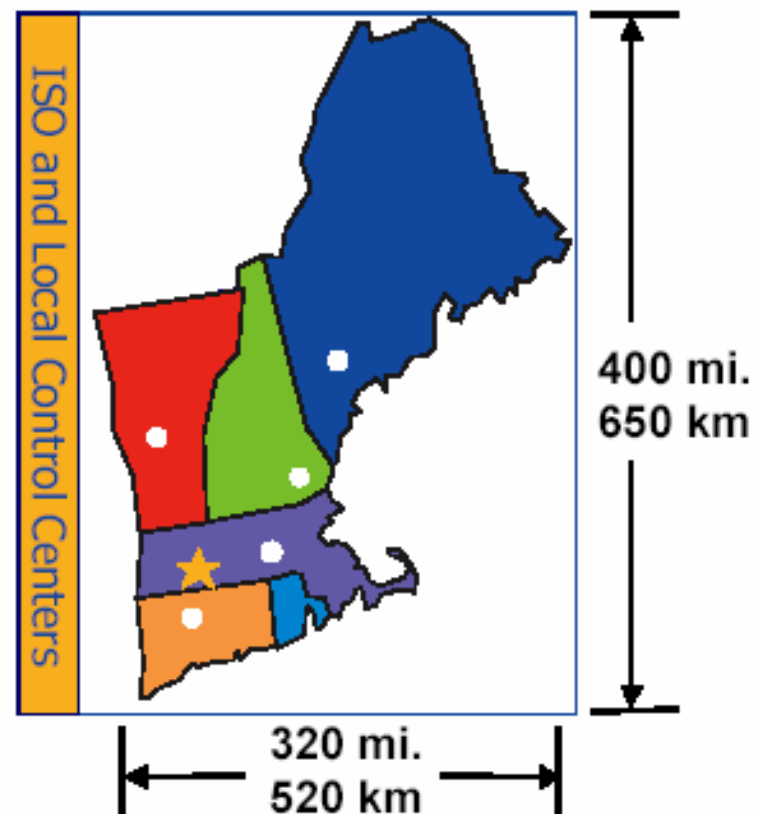

# NEPOOL

- Formed in response to October 1965 Blackout
- Originally a reliability agreement
- Evolved into a reliability and economic agreement
- New England dispatched as a single utility
- Complicated settlement process

# NEPOOL & ISO/RTO

- 1997 Interim ISO Agreement
- 2004 Settlement process for RTO status
  - ISO and Transmission owners split FERC filing rights
  - NEPOOL has “jump ball” provision on Market Rules with a 60% threshold
  - 6 sector governance (16.67% voting share)
  - Committee structure for review of rules

# Tomorrow

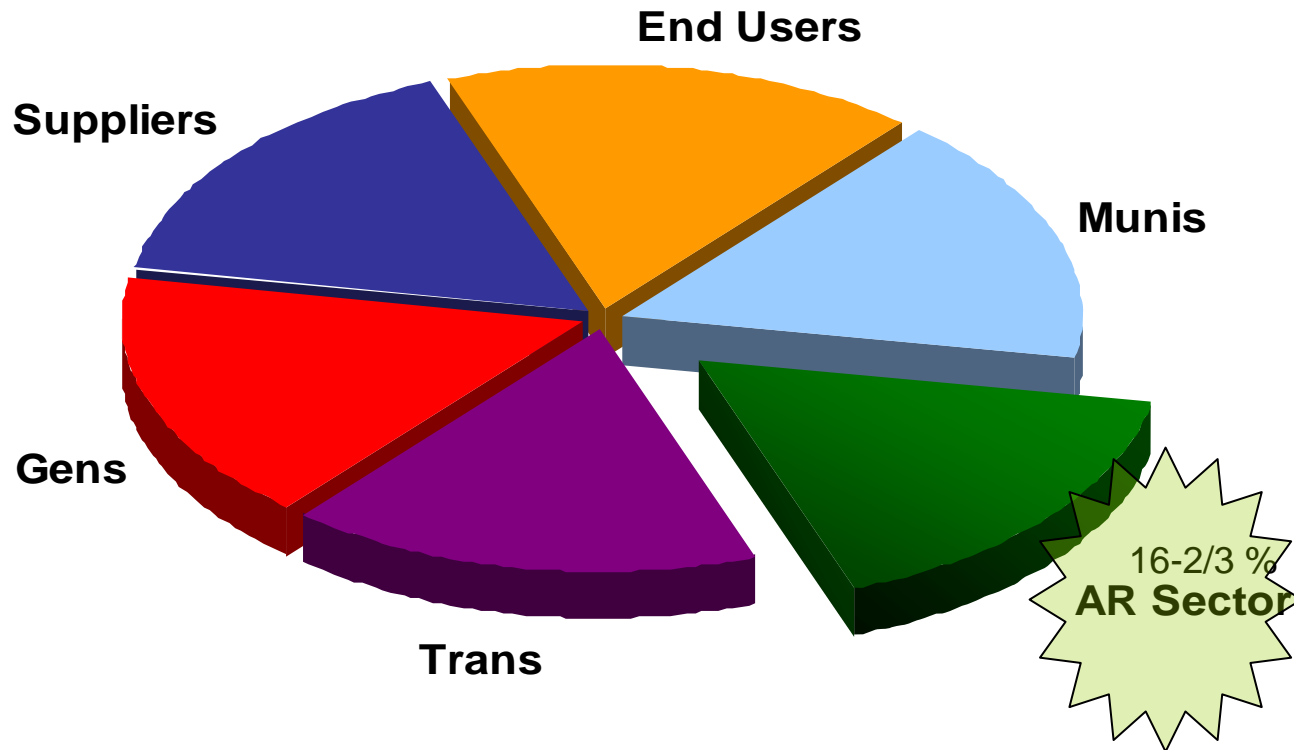

# Tomorrow

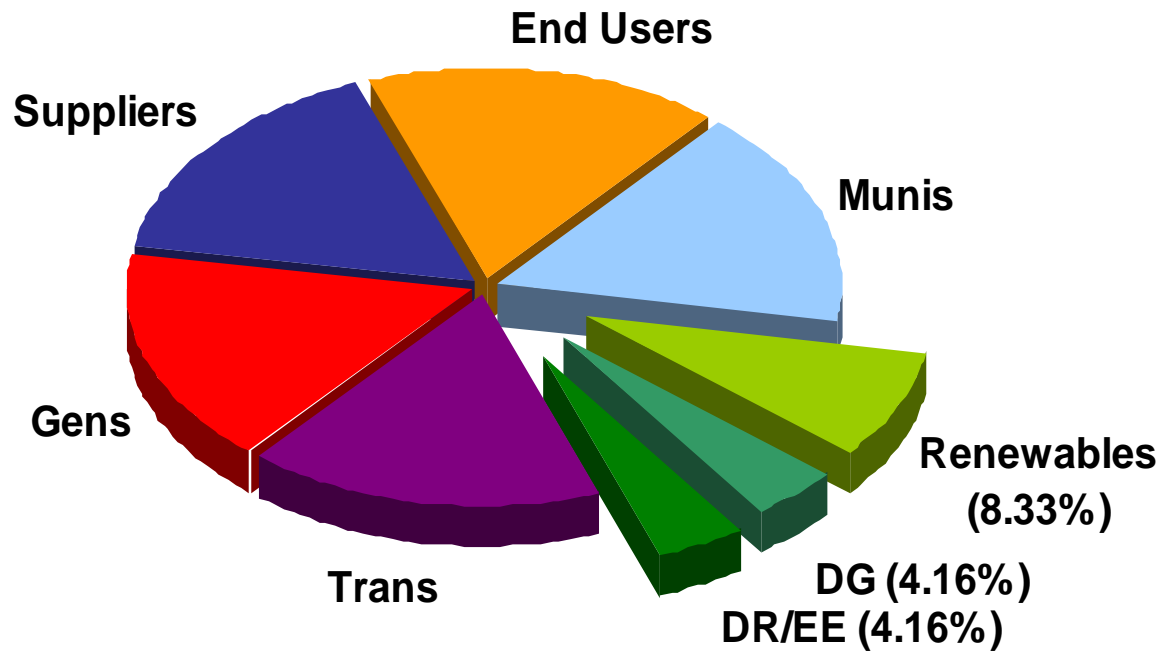

AR Sector  
16-2/3 %

# ISO New England Core Responsibilities

- Maintain system reliability
- Design and implement competitive wholesale markets
- Administer the open access transmission tariff (OATT)
- System planning

# New England Wholesale Electricity Markets

New England is ahead of the rest of the nation in terms of its restructuring efforts.

- High levels of generation divestiture
- 88% of New England's generation is unregulated. None of Vermont's
- Generation investment risk shifted away from consumers
- Proper correlation of price with supply and demand
- Continuous studies have shown markets are competitive.
- Facilitated significant bilateral contracting.
- More than 280 wholesale Market Participants

# Resource Adequacy

- Adequate resources to meet system loads (includes reserves)
- Resources include transmission, generation, demand response, and energy efficiency
- NERC planning standard: involuntary loss of load not more than “one day in ten years”

# Comprehensive System Planning

- Identify short-term and long-term concerns
- Look at solutions including:
  - Reductions in load (efficiency, demand response, on-site generation)
  - New generation (central and distributed)
  - Transmission enhancements (modifications such as PARs and capacitors, upgrades to existing lines, new lines)

# Regional Planning Process

- Annual evaluation of existing system
- Forecast future system over multiple time horizons (5y, 10y, 15y)
- Estimate load growth
- Estimates of new resource additions
- Estimate transmission upgrades/expansions
- Estimates congestion costs/savings
- Integrated and iterative process

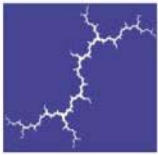

# ISO RTEP Process

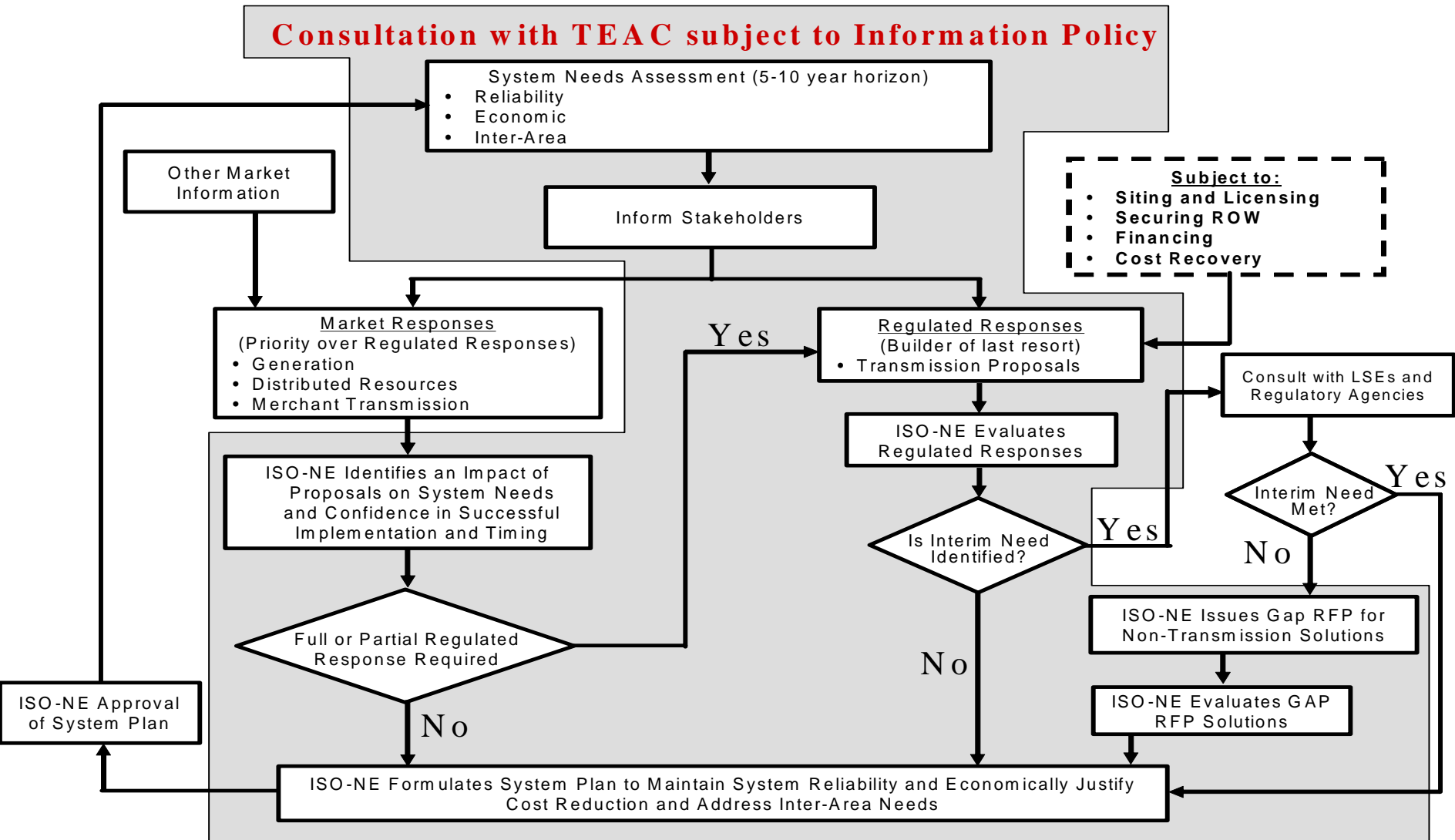

# ISO RSP Process

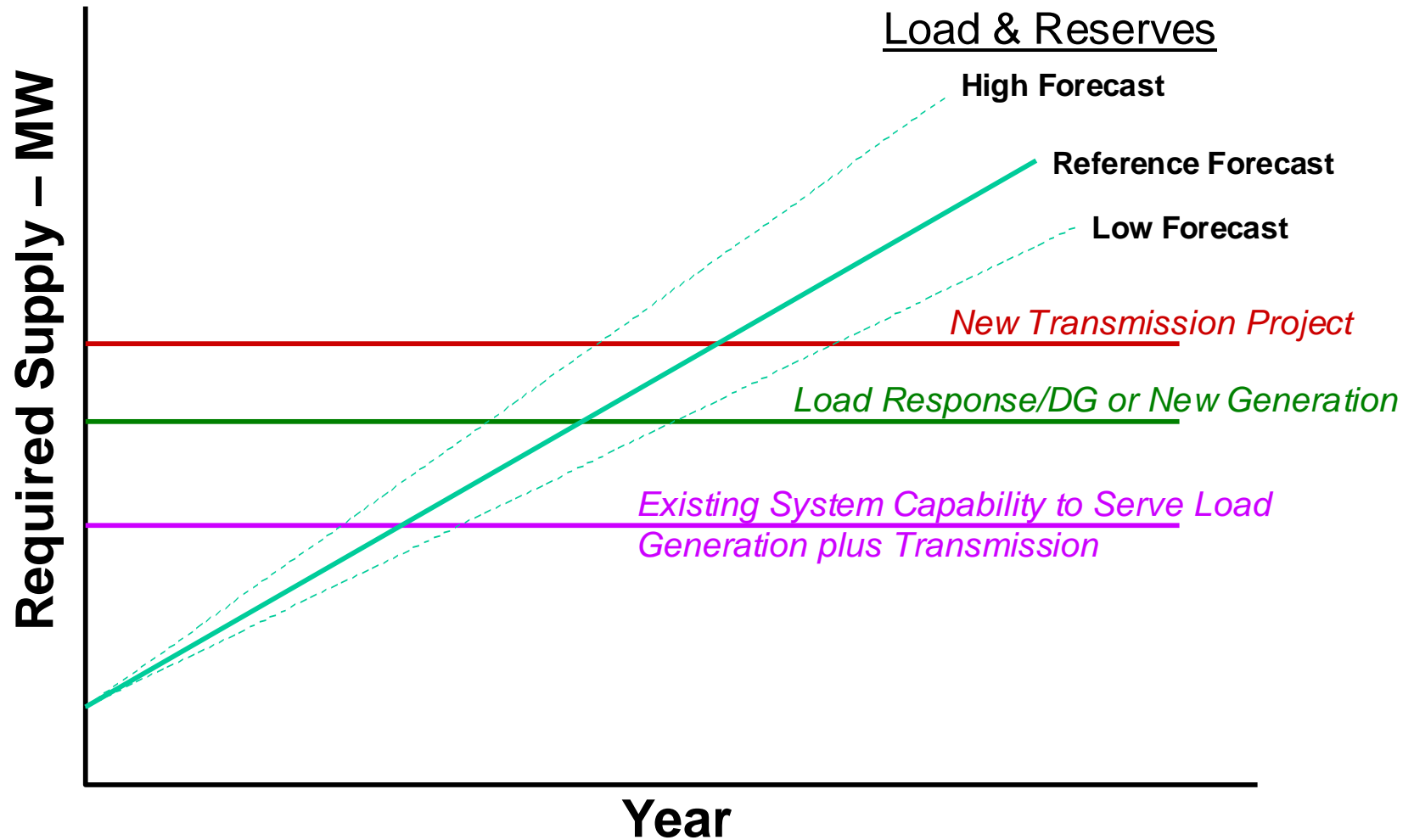

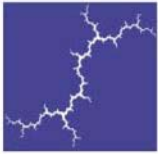

# ISO RTEP process

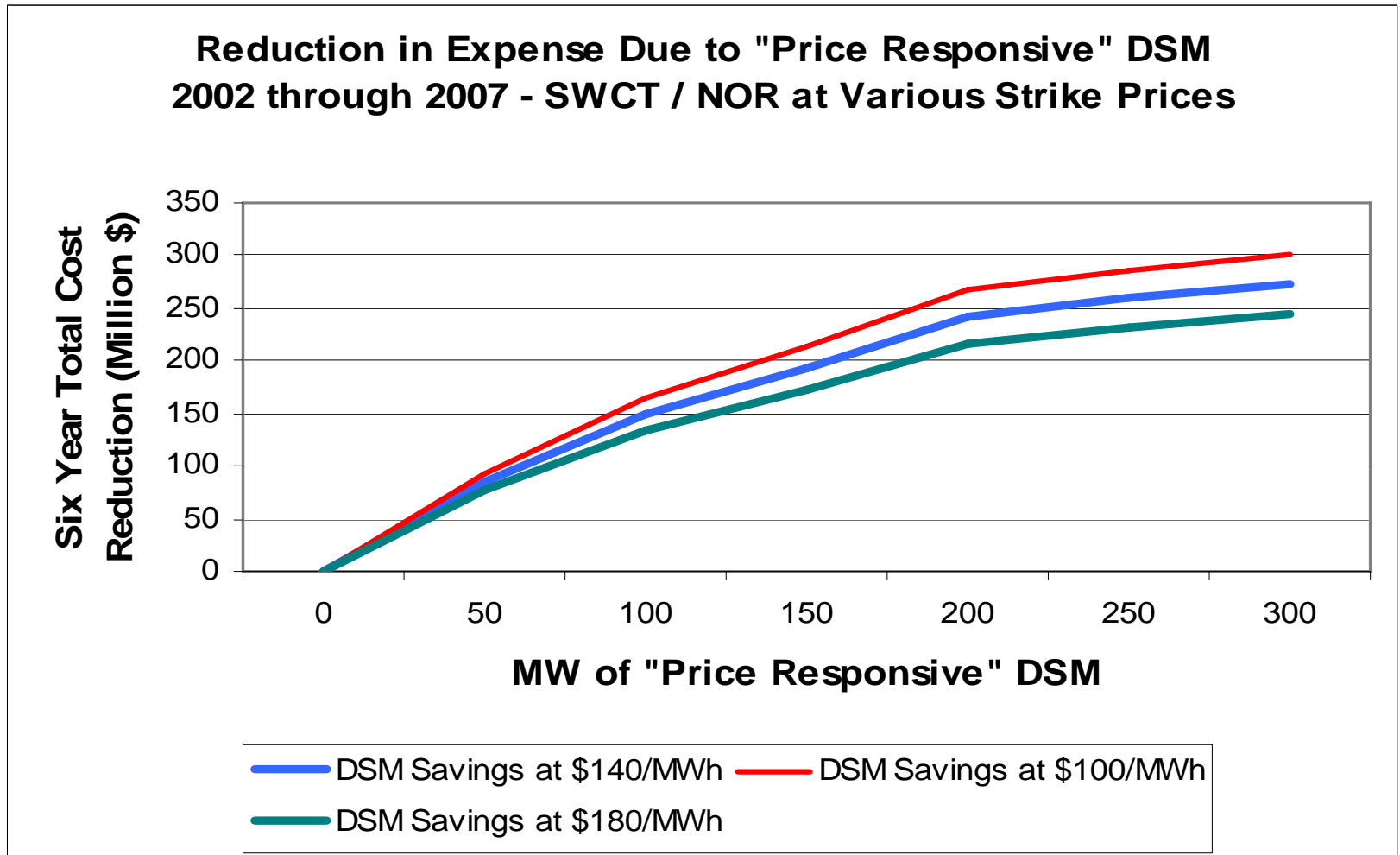

# Acronyms

- ISO/RTO: Independent System Operator or Regional Transmission Organization
- NEPOOL: New England Power Pool
- NECPUC: New England Conference of Public Utility Commissioners
- FERC: Federal Energy Regulatory Commission
- NESCOE: New England States Committee on Electricity

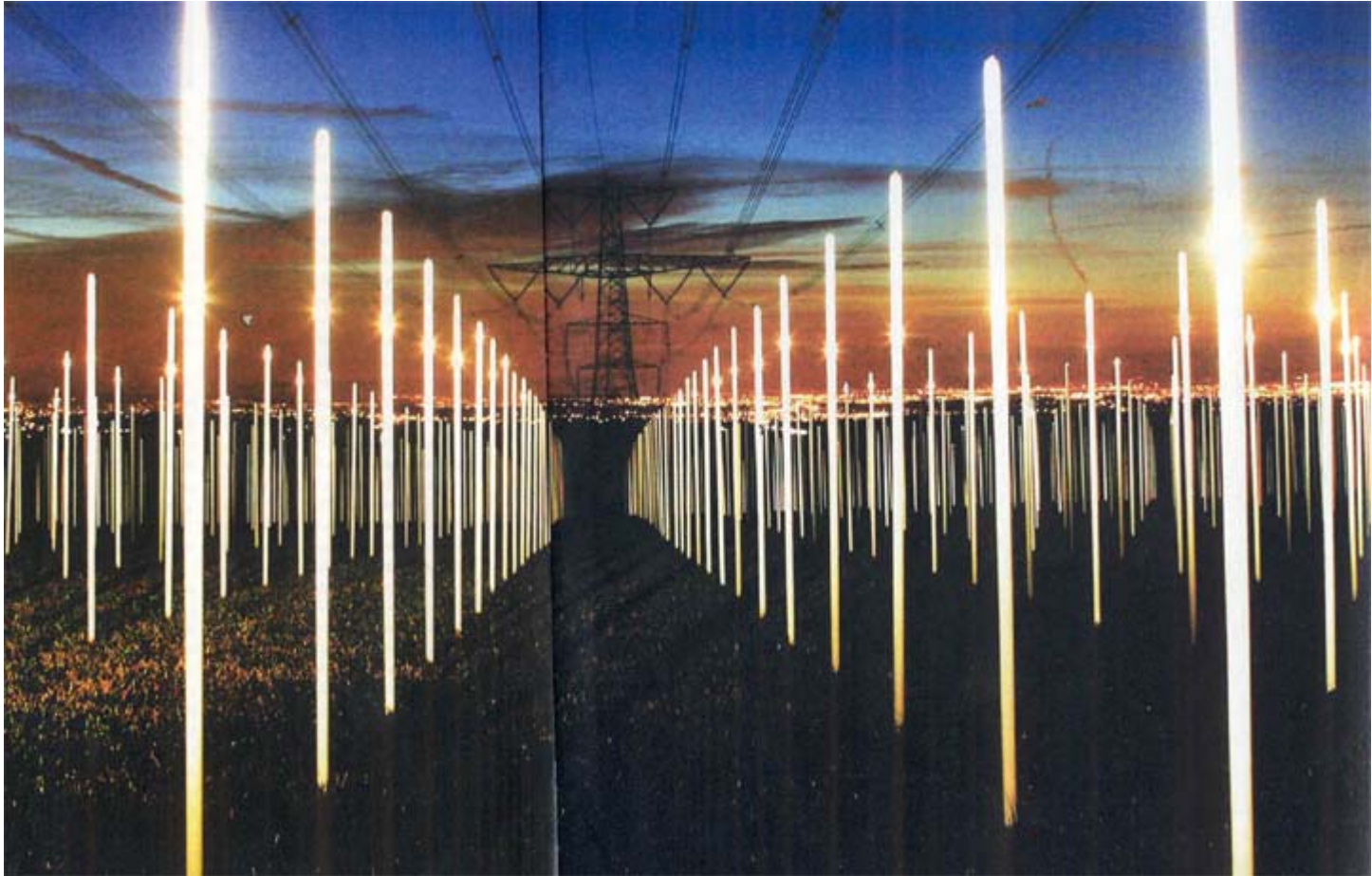

# Vermont Planning Efforts

- Mediated Modeling
  - Broad consensus concerning the inclusion of large hydro resources in all portfolios reviewed;
- Utility Collaborative Feasibility Study to Consider Instate Generation Options
- Entergy Replacement Contract/License Extension
- Formal Public Engagement Process (Act 208) – Public Workshops, Deliberative Polling, Online forum
- Twenty Year Electric Plan and Update (update released 10/06, Revised Plan 1<sup>st</sup> Quarter of '08)

# Reliability vs Economics

- **Reliability** is the ability to keep the lights on
- **Economics** is the allocation of the costs to accomplish the reliability
- The focus tonight is on economics – how are the various cost obligations incurred and how do they flow to utilities and ultimately to ratepayers.

# Pricing Comparison

Regulated Electric Pricing	Competitive Electric Pricing
<p>Cost of Service Pricing Average Costs</p> <ul style="list-style-type: none"><li>- Total costs of production, including a return on investment equal to the producer's cost of capital, divided by sales to ultimate consumers<sup>1</sup></li></ul>	<p>Supply and Demand impact pricing.</p> <ul style="list-style-type: none"><li>- Increasing or decreasing supply (generation) or demand impacts price.</li></ul>
	<p>Based on marginal pricing</p> <ul style="list-style-type: none"><li>- Marginal pricing reflects the cost to serve the next increment of load.</li><li>- Generation payment is based on marginal pricing.</li></ul>

<sup>1</sup>EIA, *Electricity Prices in a Competitive Environment - Executive Summary Oct 21, 2002.*

# Essential Features of New England Wholesale Electric Markets

- Multi-Settlement Energy Market
  - Day-Ahead and Real-Time
- Locational Marginal Pricing (LMP)
- LMP is designed to reveal the price of producing power at a specific location.
  - Over 900 locations
- Risk Management Tools
  - Bilateral Transaction
  - Day-Ahead Market
  - Financial Transmission Rights (FTRs)
- Market Monitoring and Mitigation

# Essential Features of New England wholesale electricity markets (cont)

- LMP
  - Pricing of electricity that includes three components: Energy, Congestion, and Losses
- Nodes
  - Points on the New England Transmission System at which LMPs are calculated
  - 900+ in New England

# Essential Features of New England wholesale electricity markets (cont.)

- Zones
  - Load-weighted average of Nodal prices in a Zone
  - Load settles at Zonal price
  - Eight Load Zones
- Hub
  - Predefined Nodes; straight average of 32 Nodal prices
  - Cost of congestion is typically minimized.
  - Hub was created to support bilateral trading.

# Load Zones and Pricing Hub

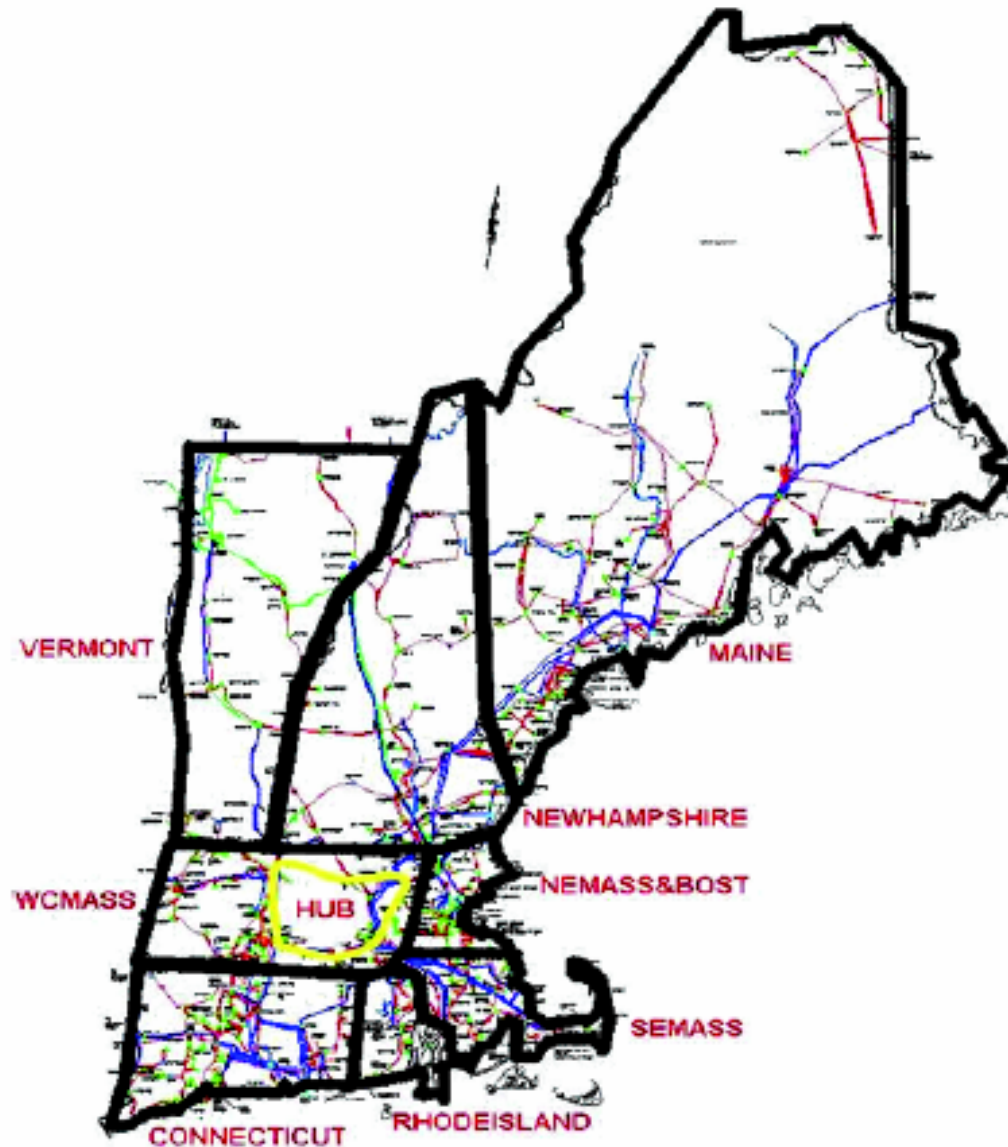

# ISO New England Wholesale Electric Markets and Products

- Electric Energy Market
  - Day Ahead Market (DAM)
  - Real Time Market (RTM)
- Ancillary Services Market
  - Forward Reserves Market (FRM)
  - Regulation Market
- Capacity Market
  - Forward Capacity Market (FCM)
    - Transition Period
- Financial Transmission Rights (FTR)
- Demand Response Programs
  - Day Ahead and Real Time

Products in **red** are required of each market participant

# Power Market

## Financial Transactions at Settlement

### Cash Flow

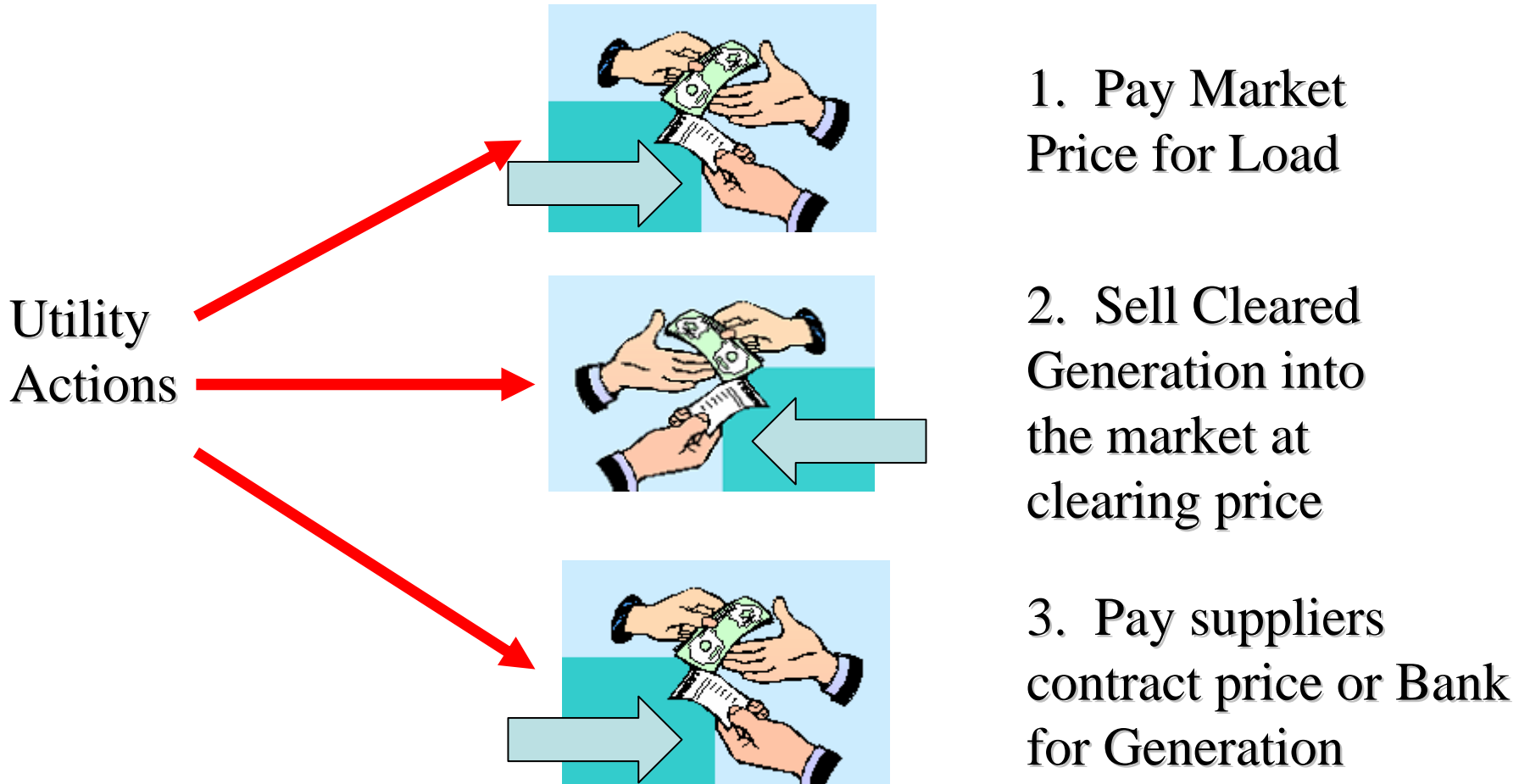

# Economic Dispatch – Marginal Pricing

Highest-priced Generator is not dispatched.

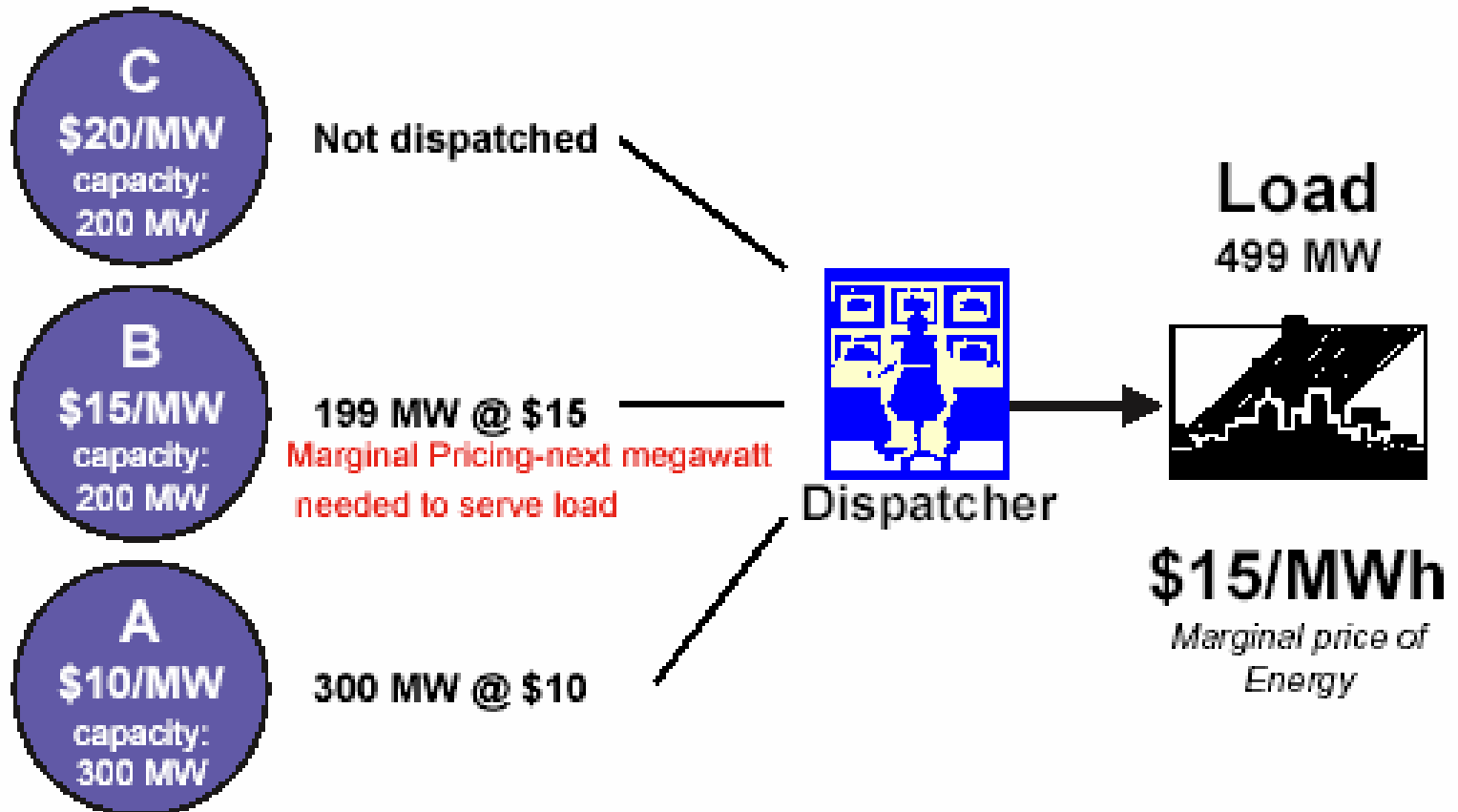

# Economic Dispatch – Marginal Pricing (cont.)

Highest-priced Generator sets price.

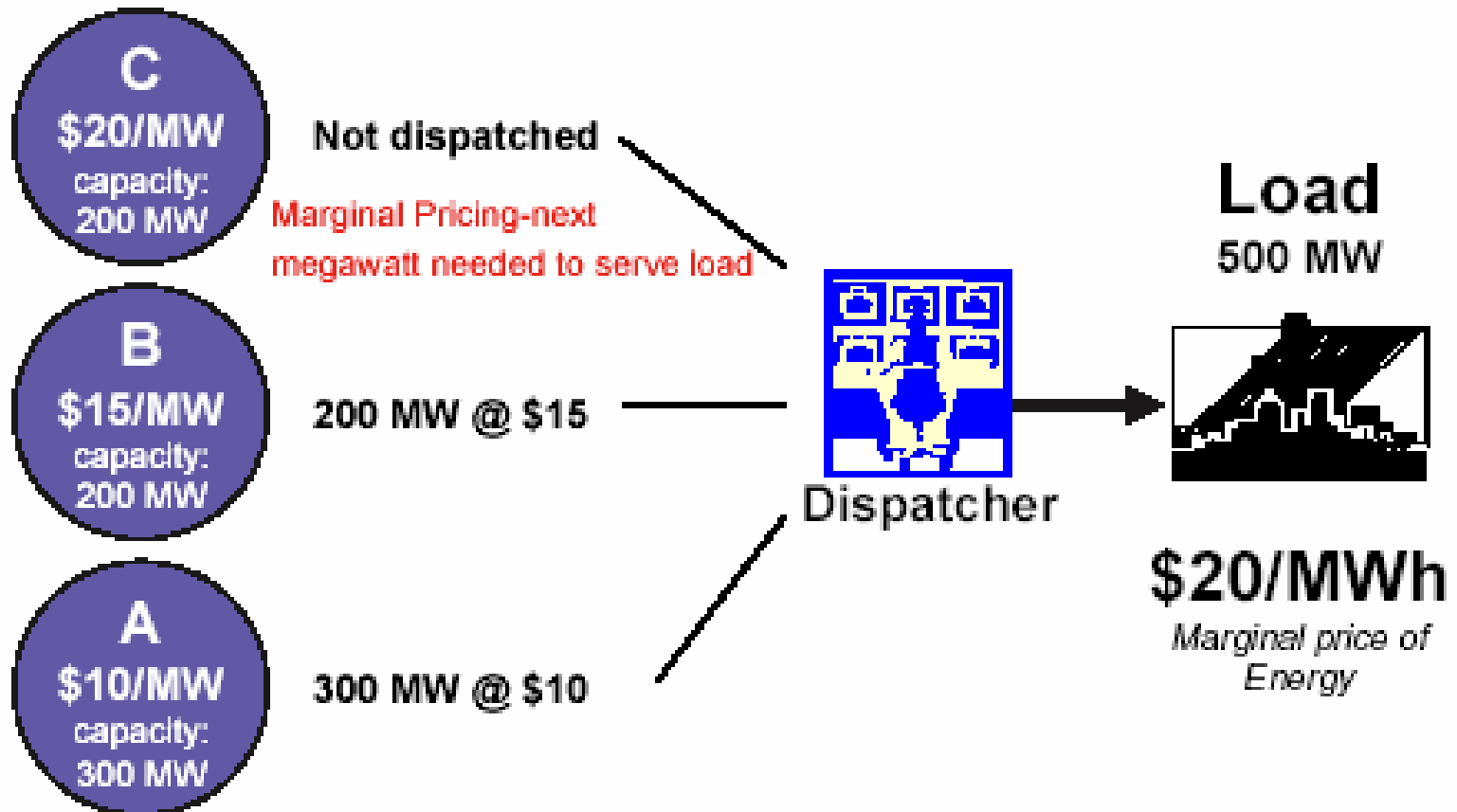

# LMP Components

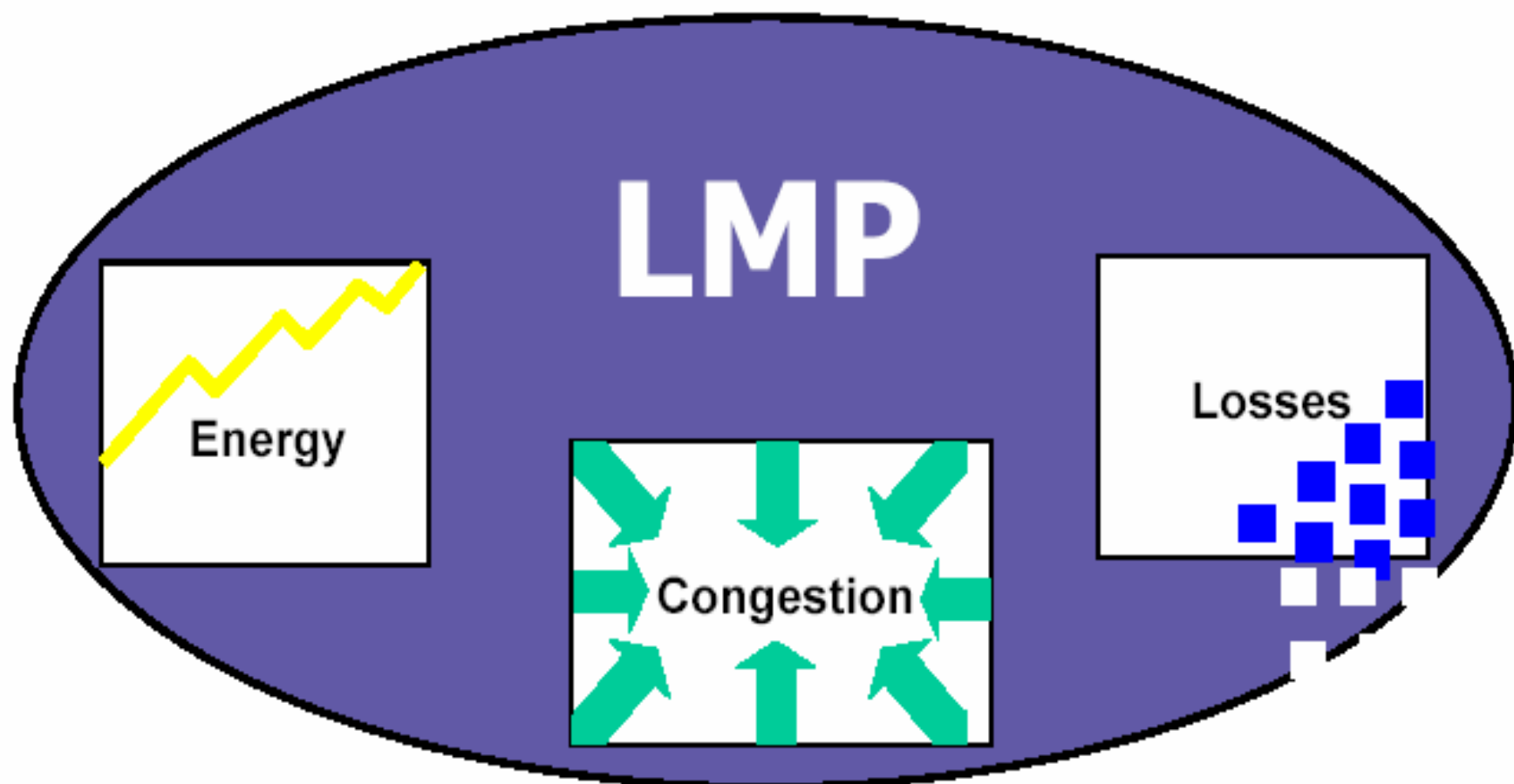

Each LMP can be **split** into three components.

# Locational Marginal Pricing

- LMP
  - If there are no system constraints
    - Energy Component is the same across New England (not including losses)
    - Congestion is zero (\$0.00)
  - If congestion occurs
    - Energy Component is the same across New England (not including losses)
    - Congestion component (+ or -) is reflected in LMP
    - Load weighted congestion sums to zero

# New England Electric Energy Markets

- **DAM - Day before Operating Day**

- DA Energy Market produces hourly schedules for production and consumption of power in advance of the Operating Day

- Supply offers and demand bids determine DA clearing price

- Creates binding financial obligations on participants that enhance price certainty

- Majority of New England Market activity is within the DAM (~\$8 – 9 Billion/year)

# New England Electric Energy Markets

- **RTM – Real Time on the Operating Day**
  - Deviations from DA bids and offers are settled at RT price
  - Actual operation of units and rebids determine RT clearing price
  - RT market is a balancing market (~ \$.5 -1. billion per year)



**DAY AHEAD**

**REAL TIME**

**REAL TIME ANCILLARY SERVICES**

**REAL TIME MARKET - ZONAL LMP - Dollars per MWh**

Valid As Of: 2007-09-25 13:20

**INSTRUCTIONS:**

Move cursor over zone to view loss and congestion pricing.  
 Move cursor over black line between zone and external interface to view actual interface flow.  
 Use the color key below for an at a glance interpretation of the market.

**PRICE COLOR KEY**

Red	\$1,001 +
Orange	\$501 - \$1,000
Brown	\$201 - \$500
Light Brown	\$151 - \$200
Light Orange	\$101 - \$150
Yellow	\$71 - \$100
Light Green	\$41 - \$70
Green	\$21 - \$40
Dark Green	\$0 - \$20
Blue	under \$0

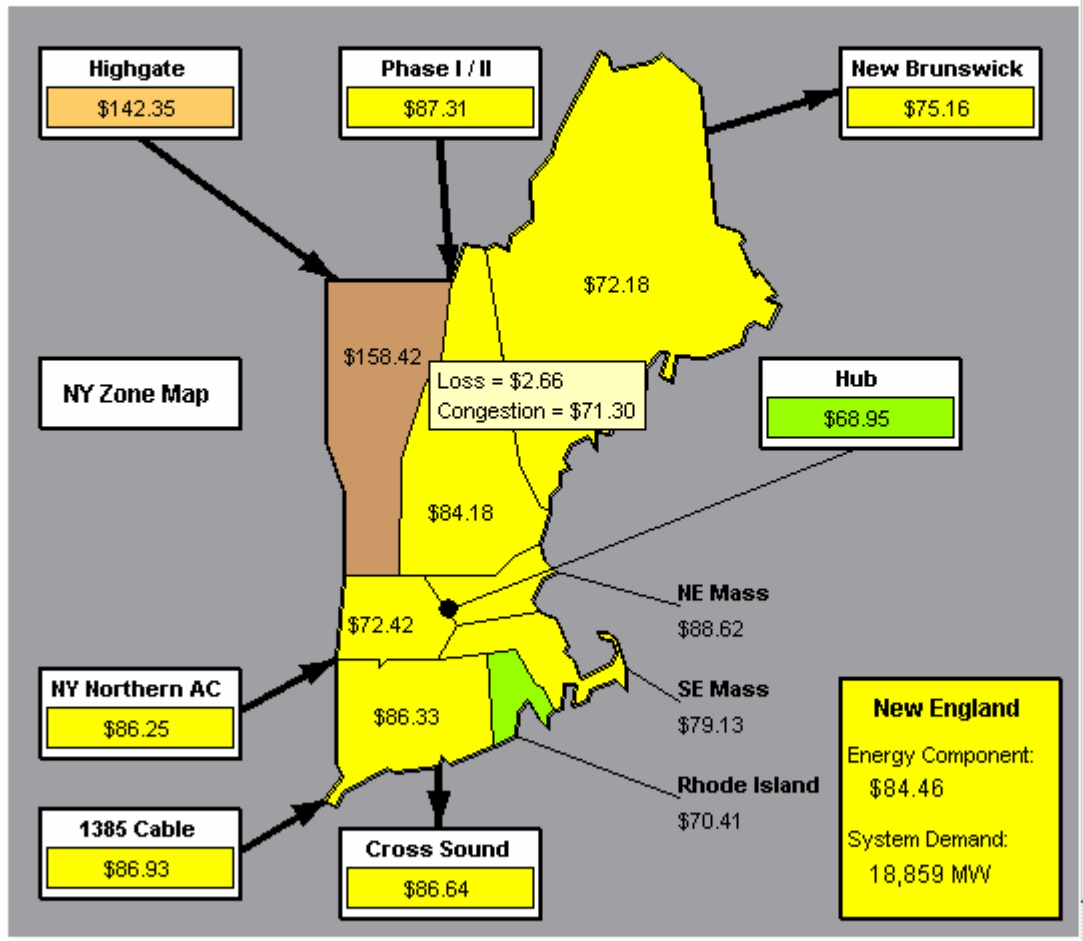

Home Help

[View Calendar for Current Notices](#)

**Power System Condition:**  
 New England **Normal**

**BINDING CONSTRAINTS:**  
 Sampling Period: 2007-09-25 13:20

Limit on 210\_LVERMORE\_89\_A  
 Contingency N/A  
 Limit on 379S\_ASCUTN\_T\_W149S-1\_A  
 Contingency N/A  
 Limit on BASE\_INTRFC\_SBRK\_S  
 Contingency N/A

Applet will automatically refresh itself with the most recent data every 5 minutes.

# **Forward Capacity (FCM) Market**

# FCM

- Forward Capacity Auction
  - Three years forward
  - Existing capacity gets one year commitment
  - New capacity to select 1 to 5 year commitment
  - Opportunities to de-list or retire at a price
- Imports, Exports, Intermittent and Demand Resources have modified treatments
- Self supply option to avoid market risks

# FCM

- Availability requirements that penalize resources unavailable in shortage hours
- Caps on penalties (monthly and annual)
- Opportunity for well-performing units to earn bonuses
- Peak Energy Rents (PER) reduce energy market revenues
- Intermittent and demand resources have different availability terms

# Transition Period

- Fixed payments for all qualifying resources
  - Dec. 1 2006-May 31, 2007 \$3.05/kW-month
  - June 1, 2007-May 31, 2008 \$3.05/kW-month
  - June 1, 2008-May 31, 2009 \$3.75/kW-month
  - June 1, 2009-May 31, 2010 \$4.10/kW-month
- No cap on resource quantity!
- No PER adjustments to transition payments
- Demand Resources qualify

# Demand Resource Potential Revenue

Hypothetical program with 10-year measure life

	Year	Size (MW)		Price		Revenue
Transition	06/07	5	\$	3.05	\$	106,750
Transition	07/08	5	\$	3.05	\$	183,000
Transition	08/09	5	\$	3.75	\$	225,000
Transition	09/10	5	\$	4.10	\$	246,000
FCM - 1	10/11	5	\$	4.50	\$	270,000
FCM - 2	11/12	5	\$	3.60	\$	216,000
FCM - 3	12/13	5	\$	2.95	\$	177,000
FCM - 4	13/14	5	\$	7.50	\$	450,000
FCM - 5	14/15	5	\$	7.50	\$	450,000
FCM - 6	15/16	5	\$	7.50	\$	450,000
		<b>10-year Revenue</b>				<b>\$ 2,773,750</b>

Funds can supplement state-funded programs, enable merchant projects, ...

# Potential Market Effect

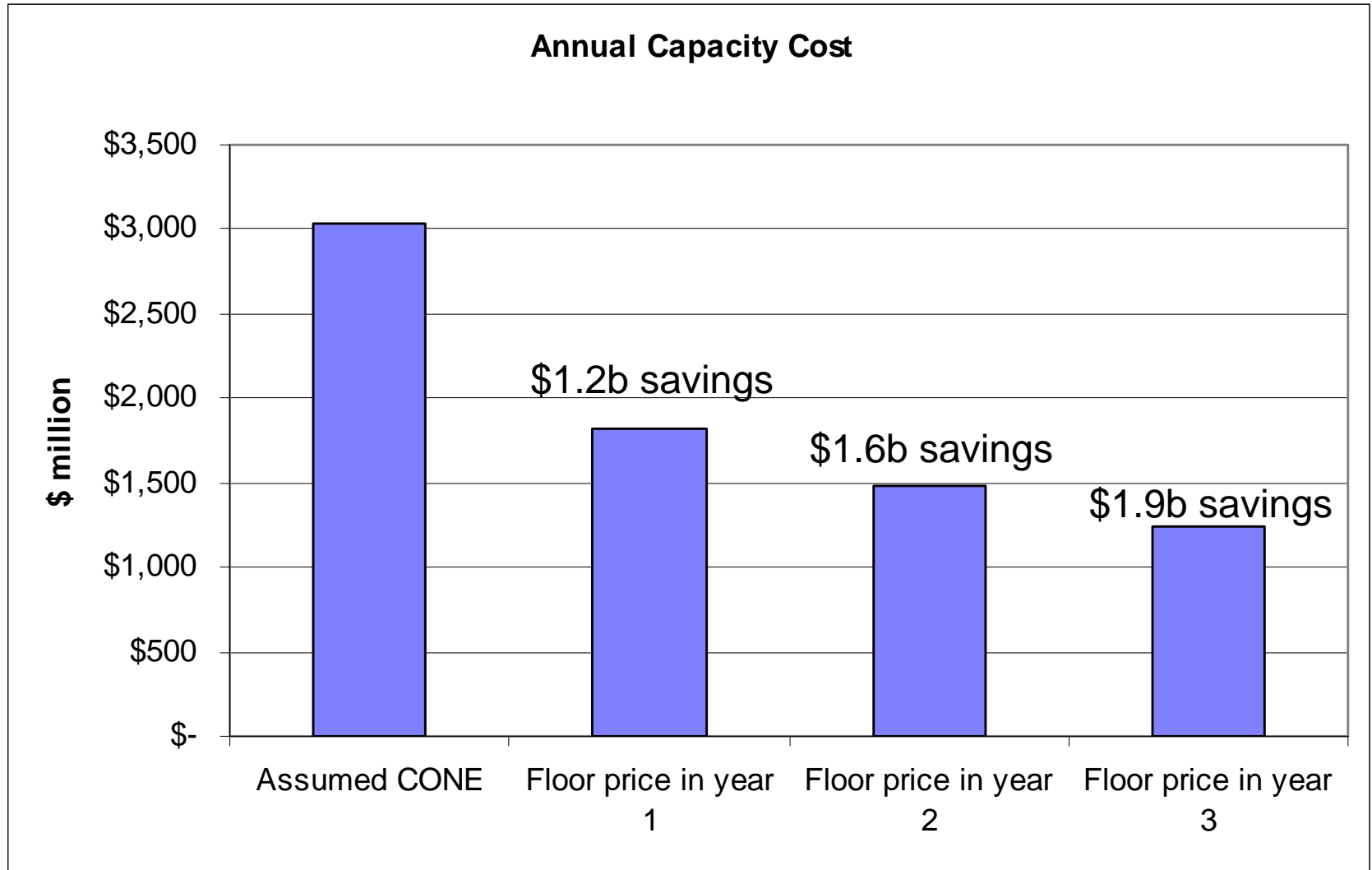

# **Transmission Charges and Cost Allocation**

# PTF Cost Allocation

- PTF costs are assigned as a percentage of peak load
  - Mass ~ 45 percent
  - CT ~ 26 percent
  - NH ~9 percent
  - Maine ~ 8 percent
  - Rhode Island ~7 percent
  - VT ~ 4 percent
- Local costs are 100 percent to the distribution company

# ISO Determinations

- ISO reviews all approved transmission upgrades for cost allocation
- Costs not related to electrical feasibility and good utility practice are not eligible for regional cost sharing
- Three examples
  - NSTAR 345kV line to Boston
  - NU 345 kV and 115 kV lines for SW CT
  - NW Reliability Project (VT)

# Pool Transmission Facility

- PTF applies to transmission function as opposed to distribution function.
- Large wires (above 115kV) have a presumption of transmission function
- 115kV and below can be primarily transmission
- PTF is paid for regionally; distribution functions are paid for locally

# Vermont Transmission Charges

Vermont utilities are billed for transmission under two tariffs

❖ **NOATT** New England Open Access Transmission Tariff

❖ Vermont Transmission Agreement (“**VTA**”)

# NOATT Charges

- VELCO and other transmission providers submit an estimate of its PTF qualified plant in service to ISO
- ISO tallies estimates of PTF costs from all transmission providers and calculates a pro rata share for each transmission provider, based on peak load per month.
- Based on VELCO estimate, ISO calculates a reimbursement rate for PTF qualified facilities.

# VTA charges

- VELCO costs for “common” facilities are pooled among all participants (Vermont Utilities)
- Net VELCO NOATT charges allocated on based on monthly peak load
- VELCO costs for “specific” facilities. After 10 years, specific facilities are transferred to common facilities.